

Effective date: 01 March 2025

Status: Approved



# Class Rules

## International 420 Class Association



The 420 was designed in 1959 by Christian Maury and was adopted as a World Sailing class in 1973.

sport / nature / technology

# INDEX

## PART I – ADMINISTRATION

### Section A – General

A.1	General Information.....	3
A.2	Language.....	3
A.3	Abbreviations.....	3
A.4	Authorities and Responsibilities.....	3
A.5	Administration of the Class.....	3
A.6	WS Rules.....	4
A.7	Amendments to Class Rules.....	4
A.8	Class Rules Variations.....	4
A.9	Interpretations of Class Rules.....	4
A.10	ICA fee ICA Plaque.....	4
A.11	Certification & certificate.....	4
A.12	Validity of Certificates.....	5
A.13	Re-Certification.....	5

### Section B – Boat Eligibility

B.1	Certificate.....	6
B.2	Certification marks.....	6
B.3	ICA Sail buttons – stickers.....	6
B.4	ICA Plaque.....	6
B.5	Builder's Plaque.....	6

## PART II – REQUIREMENTS AND LIMITATIONS

### Section C – Conditions for Racing

C.1	General.....	7
C.2	Crew.....	7
C.3	Personal Equipment.....	7
C.4	Advertising.....	8
C.5	Portable Equipment.....	8
C.6	Boat.....	8

C.7	Hull.....	9
C.8	Hull Appendages.....	9
C.9	Rig.....	10
C.10	Sails.....	11

### Section D – Hull

D.1	Certification.....	14
D.2	Builders.....	14
D.3	Building & Materials for Building.....	14
D.4	Assembled Hull.....	15
D.5	Hull Weight.....	20
D.6	Corrector Weights.....	20

### Section E – Centreboard, rudder & tiller

E.1	Rules.....	21
E.2	Manufacturer.....	
	21E.3	
	Centreboard.....	
	21	
E.4	Rudder.....	22

### Section F – Rig

F.1	Rules.....	24
F.2	Mast.....	24
F.3	Boom.....	26
F.4	Spinnaker Pole.....	26
F.5	Rigging & fittings.....	27

### Section G – Sails

G.1	Measurement.....	28
G.2	Certification.....	28
G.3	Mainsail.....	29
G.4	Headsail.....	31
G.5	Spinnaker.....	32

## Section A – GENERAL

### A.1 GENERAL INFORMATION

**A.1.1** The International 420 **class rules** are **closed class rules**.

**A.1.2** The 420 is a one-design class. The intention of these rules is to ensure that the **boats** are as alike as possible in all respects affecting performance, in order that **crews** may compete against each other on level terms.

**A.1.3** These rules are complementary to the Lines plan (plan des formes), the building specifications (Drawing N° 5), the International 420 Class Association (ICA) **rudder** blade drawing and the 420 International Measurement Form (IMF). The current issue of these official documents is listed at the end of this document. These items, however complete, cannot anticipate every situation that may arise. If a point is not clearly covered, a ruling shall be obtained from WS through the ICA technical Committee.

### A.2 LANGUAGE

**A.2.1** The official language of the Class is English and in the event of dispute over interpretation, the English text shall prevail.

**A.2.2** The word “shall” is mandatory and the word “may” is permissive.

**A.2.3** The term “permanent” shall mean unable to be removed with simple tools, or fixed with glue or rivets. For **limit marks**, it shall mean unable to be removed and repositioned without destroying them.

**A.2.4** All units are metric and all dimensions, unless otherwise stated, are in millimetres.

### A.3 ABBREVIATIONS

<b>A.3.1</b>	WS	World Sailing
	MNA	WS Member National authority
	ICA	International 420 Class Association
	IMF	420 International Measurement Form
	NCA	National 420 Class Association
	ERS	Equipment Rules of Sailing
	RRS	Racing Rules of Sailing

### A.4 AUTHORITIES AND RESPONSIBILITIES

**A.4.1** The **class rules authority** is WS, which shall co-operate with the ICA in all matters concerning these **class rules**.

**A.4.2** Neither WS, an MNA, the ICA, an NCA, a **certification authority**, or a **certification measurer** are under any legal responsibility in respect of these **class rules** and the accuracy of measurement, nor can any claims arising from these be entertained.

**A.4.3** Notwithstanding anything contained herein, the **certification authority** has the authority to withdraw a **certificate** and shall do so on the request of WS.

### A.5 ADMINISTRATION OF THE CLASS

The Class is administered by the ICA, in conjunction with WS. The ICA may delegate parts or all of its functions, as stated in these **class rules**, to an MNA or an NCA.

## A.6 WS RULES

These **class rules** shall be read in conjunction with the current version of the ERS. When a term is used in its defined sense, it is printed in **bold** type if defined in the ERS and in *italic* type if defined in the RRS.

## A.7 AMENDMENTS TO CLASS RULES

A.7.1 Amendments to these **class rules** shall be proposed by the ICA and are subject to the approval of WS in accordance with WS regulations.

## A.8 CLASS RULES VARIATIONS

A.8.1 At World and Continental Championships and other ICA-sanctioned events the notice of race and/or the sailing instructions may change the class rules only with the agreement of both the ICA and WS.

A.8.2 At other events the notice of race and/or the sailing instructions may change the **class rules** only with the written agreement of the ICA to an official request by the local NCA and/or MNA.

## A.9 INTERPRETATION OF CLASS RULES

### A.9.1 GENERAL

Except as provided by A.9.2, interpretation of these **class rules** shall be made by WS in conjunction with the ICA. Request for an interpretation shall be made in accordance with WS regulations.

### A.9.2 AT AN EVENT

Any interpretation of **class rules** required at an event may be made by the ICA Technical Committee in consultation with the event chief measurer. Such interpretations shall be valid only during the event, and the ICA shall, as soon as practical after the event, inform WS of such an interpretation.

## A.10 ICA FEE, ICA PLAQUE

A.10.1 The Sail number for each boat is allocated by the ICA and specified on the ICA Plaque.

A.10.2 The ICA, after having received the class fee, shall send to the licensed builder the ICA Plaque, with the sail number allocated to the **boat**.

A.10.3 Competitors may use the sail number of any hull still owned by them, on any boat chartered or owned by them.

## A.11 CERTIFICATION AND MEASUREMENT CERTIFICATE

A.11.1 For a **hull** not previously **certified**, **certification control** for all items to be measured and to be in conformity with the Official documents shall be carried out by a **certification measurer**, and the details entered into the IMF which, when completed, shall be supplied to the owner by the builder in two copies.

A.11.2 **Certification control** shall be carried out only by **certification measurers** appointed both by their MNA and the ICA. A **certification measurer** shall not perform certification control on any part owned, designed or build by him, or in which he is an interested party, or has a vested interest, except where permitted by these **class rules**.

A.11.3 The IMF is necessary to obtain the measurement **certificate**. The measurement **certificate** is obtained as follows:

The owner shall send the IMF together with any registration fee to the **certification authority** in the country where the **boat** is to be registered. Upon receipt of a satisfactorily completed IMF and the fee, the **certification authority** issues the measurement **certificate** to the owner. The **certification authority** shall retain a copy of the IMF.

## **A.12 VALIDITY OF THE MEASUREMENT CERTIFICATE**

**A.12.1** A **certificate** is still valid after an alteration of the **corrector weights** only if the **hull** is re-weighed by a **certification measurer**. When the **hull** is re-weighed, the measurer shall enter the details on the IMF and the measurement **certificate** shall be endorsed by the certification authority.

**A.12.2** A measurement **certificate** becomes invalid upon:

- (a) Change of ownership,
- (b) Alterations other than permitted routine maintenance such as small repairs, painting, sanding and polishing to items required by the IMF to be measured,
- (c) Withdrawal by the **certification authority**,
- (d) The issue of a new **certificate**.

## **A.13 RE-CERTIFICATION**

**A.13.1** Upon change of ownership, the new owner shall apply to the **certification authority** where the **boat** will be registered for a new measurement **certificate**. The application shall include the old measurement **certificate**, the original IMF, and any registration fee that may be required. A new measurement **certificate** shall then be issued to the new owner.

**A.13.2** Upon alteration or repair to an item required by the IMF to be measured, the relevant item shall be re-measured by a **certification measurer** and the details entered on the IMF. The owner shall apply for a new measurement **certificate** (see A.13.1 for the procedure).

**A.13.3** When the **certificate** has become invalid under A.12.2(c), the **certification authority** may issue a new **certificate** at its discretion.

## **Section B – BOAT ELIGIBILITY**

For a **boat** to be eligible to race, the rules in this section shall be complied with.

### **B.1 CERTIFICATE**

No **crew** shall take part in class races unless the **boat** has a valid measurement **certificate**, in English or with English subtitles, including **corrector weight** details.

### **B.2 CERTIFICATION MARKS**

Each sail shall carry a valid **certification mark** according to G.2.1.

### **B.3 ICA SAIL BUTTONS - STICKERS**

Each **sail** first certified after 1st March 2005 shall have permanently fixed an officially numbered ICA royalty sail button or sticker.

### **B.4 ICA PLAQUE**

The ICA Plaque shall be affixed to the **hull**, as specified in D.1.5. In case of loss, a replacement plaque shall be obtained from WS.

### **B.5 INTERNATIONAL 420 BUILDER'S PLAQUE**

The builder's Plaque shall be affixed to the hull, as specified in D.1.5

## PART II – REQUIREMENTS AND LIMITATIONS

---

The **crew** and the **boat** shall comply with the rules in Part II when *racing* and when *rules* specify. The Notice of Race may specify that compliance shall be in effect from the moment equipment is presented for event inspection. Measurement to check conformity with rules of Section C is not part of **certification control**. Measurement shall be carried out in accordance with the current version of ERS except where varied in this Part.

### Section C – CONDITIONS FOR RACING

#### C.1 GENERAL

##### C.1.1 RRS CHANGES

(a) If the average wind speed is clearly over 13 knots across the course the race committee may signal in accordance with RRS Appendix P5 that pumping, rocking and ooching are permitted. This changes rules RRS 42.2(a), RRS 42.2(b), RRS 42.2(c).

(b) A **crew** member shall use no device designed to position his body outboard other than a **crew harness**, hiking straps and hiking aids worn under the thighs. This changes RRS 49.1

(c) See C.10.3.a) & C.10.5.a) for changes to RRS Appendix G.

(d) The total weight of personal equipment worn, excluding **crew harness** and clothing (including footwear) worn below the knee shall not exceed 9 kg. The **crew harness** shall not be filled with **ballast**, shall float in fresh water and shall have a maximum weight of 3 kg. This changes RRS 50.1(b)

#### C.2 CREW

##### C.2.1 LIMITATIONS

(a) The **crew** shall consist of two persons, each in contact with the **boat**.

(b) No **crew** member shall be substituted during an event without the approval of the Race Committee.

(c) The **crew** shall be current members of a NCA which shall be in good standing with the ICA.

##### C.2.2 RESPONSIBILITY OF THE CREW

It is the **crew's** responsibility to ensure that the **boat** and **personal equipment** comply with the **class rules** when *racing*.

#### C.3 PERSONAL EQUIPMENT

##### C.3.1 MANDATORY

When afloat, each **crew** member shall wear **personal flotation device** to the minimum standard ISO 12402-5 (Level 50), or USCG Type III, or AS 4758 Level 50, or equivalent. Inflatable buoyancy vests are not permitted.

##### C.3.2 OPTIONAL

(a) A **trapeze** may be used, but only one member of the **crew** shall use a **crew harness**. A **crew** member using a **trapeze** shall be in contact with the **hull** at all times except in the situation of accidental movement and or a maneuver.

(b) Electronic or mechanical timing devices which don't have any other function / capability. No other electronic device shall be carried by the crew on board.

## C.4 ADVERTISING

### C.4.1 CATEGORY

Advertising including competitor advertising is permitted in accordance with WS Regulation 20 - Advertising code.

## C.5 PORTABLE EQUIPMENT

### C.5.1 FOR USE

#### (a) OPTIONAL

- (1) Hand bailers, buckets, sponges
- (2) One compass fixed to a mounting bracket. The compass shall not recess into either side tank or foredeck. The mounting bracket may be attached to the **mast** or may be used to close the mast gate. If electronic, only a compass with heading, heading memory and timing functions is permitted; Electronic or mechanical timing devices, which shall be removable.

The Notice of Race or Sailing Instructions may require or permit additional electronic equipment to be carried aboard (such as tracking devices, cameras etc.)

- (3) Tools and spare parts such as blocks, shackles, ropes etc.

### C.5.2 NOT FOR USE

#### (a) OPTIONAL

- (1) One paddle

#### (b) MANDATORY

- (1) The **boat** shall be fitted with a floating towing rope of a minimum length of 8 m and minimum diameter of 8 mm, secured to the **mast** and stored inside one of the spinnaker bags.

## C.6. BOAT

### C.6.1 WEIGHT

The boat shall have a minimum **boat weight** of 101 kg. A compass with associated bracket, if present, shall be included in the **boat weight**. **Corrector weights**, including any required by D.6, shall have a maximum weight of 2 kg.

### C.6.2 FITTINGS

**Rigging** and fittings listed here under shall be fitted and used only as specified. Except where otherwise specified, the direction of the control lines, sheets, and ropes shall not be modified by means of shackles, rings, loops thimbles or holes in the **boat**. Fittings listed here under shall comply with the current **class rules**. All fittings, fastenings and local reinforcement for fittings shall be only for their normal purpose and shall not be used to increase the weight of the boat.

- C.6.3 Non-slip material, tape and low-friction material not exceeding 4 mm in thickness may be added to the **boat** as long as it does not change the stiffness of the respective part.



## C.7 HULL

### C.7.1 LIMITATIONS

(a) Only one **hull** shall be used during an event except in case of loss or damage beyond **repair**. Such replacement may be made only with the approval of the event Technical Committee or, in its absence, the Race Committee.

### C.7.2 MODIFICATIONS AND MAINTENANCE

(a) The hull shell, deck, bulkheads, centreboard case and cockpit floor as supplied by the licensed builder shall not be **modified** in any way except as permitted by these **class rules**.

(b) Routine **maintenance** is permitted without re-measurement and re-**certification**.

(c) If any hull moulding is **repaired** in any other way than described in C.7.2.(a), a **certification measurer** shall verify on the **certificate** that the external shape is the same as before the repair and that no substantial increase in stiffness, or other advantage has been gained as a result of the repair. The **certification measurer** shall also describe the details of the repair on the **certificate**

### C.7.3 FLOTATION

(a) The **hull** shall have two side buoyancy tanks and one in the front. At initial **certification control**, the measurer shall check the water-tightness of the buoyancy tanks, inspection ports and drain plugs. If the buoyancy is unsatisfactory, the measurer shall not sign the IMF until satisfactory remedial measures have been taken. Thereafter, it is the responsibility of the competitor/owner to ensure the water-tightness of these tanks.

(b) Inspection port covers and drainage plugs shall be kept in place when *racing*.

## C.8 HULL APPENDAGES

### C.8.1 LIMITATIONS

Only one **centreboard** and one **rudder** blade shall be used during an event except in case of loss or damage beyond **repair**. Such replacement may be made only with the approval of the event Technical Committee or, in its absence, the Race Committee.

### C.8.2 CENTREBOARD

#### (a) USE

The **centreboard** shall be fitted by means of an axis pin through a hole in the centreboard case, which may include a bushing. When fully raised, no part of the **centreboard** shall project below the **hull** surface.

### C.8.3 RUDDER

#### (a) USE

The **rudder** blade shall be in its fully lowered position as dictated by the rudder downhaul or the safety pin.

No part of the **rudder** blade, when fully lowered, shall extend more than 540 mm below the HDP. The leading edge of the **rudder** blade shall not be forward of a vertical line through the HDP (see measurement diagram 2).

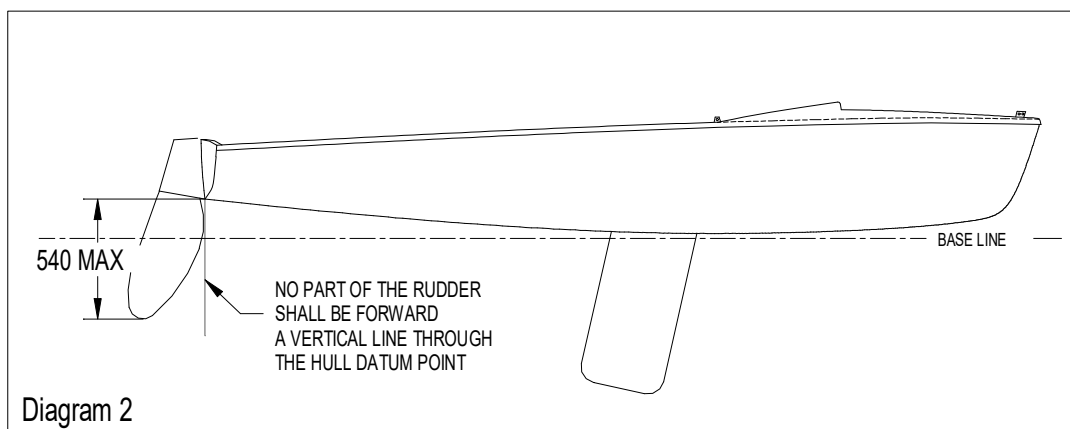

#### C.8.4 MAINTENANCE & REPAIR

Routine **maintenance** and **repairs** are permitted.

#### C.9 RIG

##### C.9.1 LIMITATIONS

Only one **mast**, **boom** and **spinnaker pole** shall be used during an event, except in case of loss of damage beyond **repair**. Such replacement may only be made with the approval of the event Technical Committee or, in its absence, the Race Committee.

##### C.9.2 MAST

###### (a) USE

(1) The fore and aft bend of the **mast** at the mast partner level may be limited by

- chocks
- an optional system of single piece of rope working on the front face of the mast spar, one attachment, one grip and one cleat without moving parts, on top of the mast partner.
- an optional system of single piece of rope working on the aft face of the mast spar, one attachment, one grip and one cleat without moving parts, on top of the mast partner.

With the mast spar in its most forward position, the grip or end of rope of the aft bend control shall not be more than 150 mm from the mast partner. With the mast in its aft most position the grip of the forward bend control shall not be more than 150 mm from the mast partner.

(2) The mast heel position shall not be adjusted on the mast step when *racing*.

(3) Adjustable **spreaders** –if used- shall not be able to be remotely controlled, and shall not be adjusted when *racing*.

(4) The effective length of the **shrouds** shall not be adjusted when *racing*.

(5) The **forestay** under tension shall be entirely in metal and shall prevent the **mast** from disengaging from the mast partners. To meet this requirement the widest section of the **mast** shall be within the mast partners when the **mast** rakes under its own weight and the **forestay** comes under tension, as in Diagram 3. The **forestay** shall be connected to

the stemhead fitting with either: a shackle, a rigging plate with holes and pins, a steel wire rope stop of minimum diameter of 2 mm or any combination of the above. Elastic rope tied on the forestay and the stemhead is permitted.

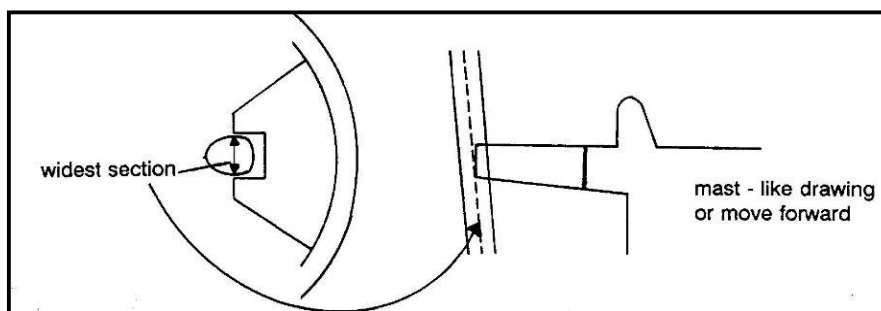

DIAGRAM 3

### C.9.3 MAINTENANCE & REPAIR

(a) Routine **maintenance** and **repairs** are permitted.

### C.10 SAILS

#### C.10.1 MAINTENANCE

(a) Routine **maintenance** and **repairs** such as sewing, mending and patching is permitted without re-**certification**. **Modified sails** shall be re-**certified** and the **certification measurer** shall place a new **certification mark** on the **sail** with the new date of **certification control**.

#### C.10.2 LIMITATIONS

(a) Not more than one mainsail, one jib and one spinnaker shall be carried aboard when *racing*.

(b) Not more than one mainsail, one jib and one spinnaker shall be used during an event, except when a sail has been lost or damaged beyond **repair**. Such replacement may be made only with the approval of the event Technical Committee, or, in its absence, the Race Committee.

#### C.10.3 MAINSAIL

##### (a) IDENTIFICATION

Identification shall comply with the RRS Appendix G except where mentioned hereunder:

As an alteration to RRS Appendix G 1.3 (a), the following items shall be positioned on each side of the **sail** as follows:

(1) National letters above and below and adjacent to the second batten from the top, port and starboard not overlapping each other, those on starboard side being uppermost.

(2) Sail numbers above and below and adjacent to the third batten from the top, port and starboard not overlapping each other, those on starboard side being uppermost.

(3) Mainsails used in women's only events shall carry a red rhombus (length of diagonals minimum 240 mm, maximum 260 mm) above the top batten pocket on both sides. The position should be approximately in the centre of the triangle formed by the top **batten pocket** and the mainsail **head**. The rhombus may be retained for racing in other events.

(4) The 420 mainsail insignia as per G.3.1 may be replaced by a gold version conforming to the same dimensions when at least one member of the **crew** is an Int. 420 Class World Champion.

(5) When required by a Notice of Race, a helmsman's national flag, nominal size 740 x 443 mm, shall be applied to each side of the mainsail, placed as shown in the Figure "Mainsail Flag Location", so that the shortest distance of the upper aft corner of each flag

is between 50 and 100 mm from the leech and the lower edge between 50 and 100 mm above the lowermost batten pocket. The flags shall be made by an ICA-approved manufacturer as listed at:

<https://www.sailing.org/classes/420/#Documents>

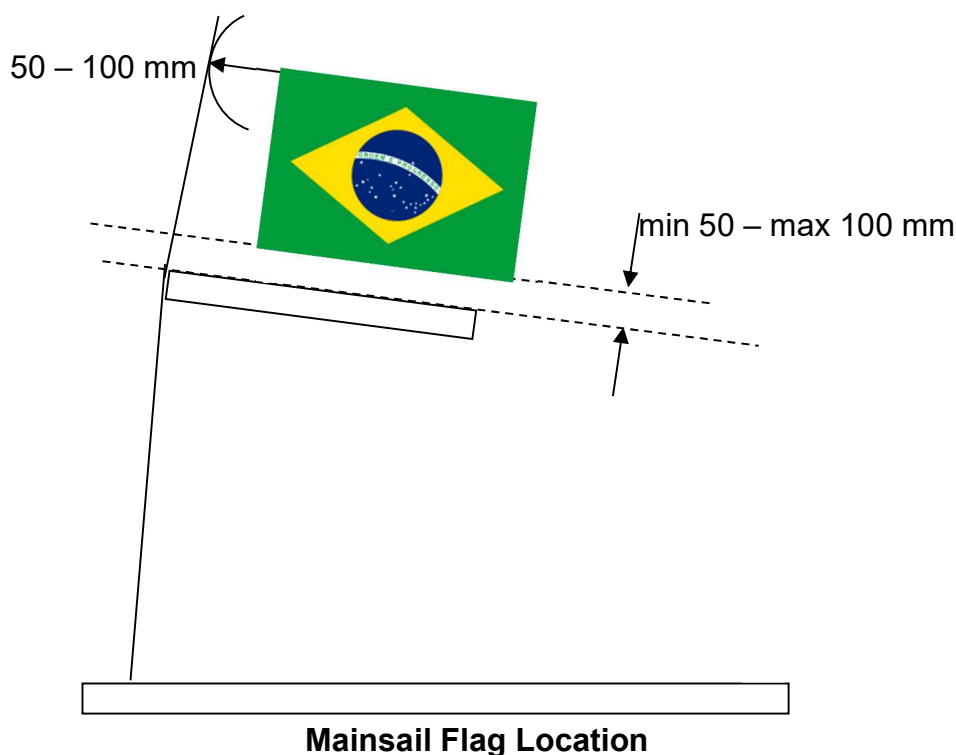

(6) Numbers and letters shall be in red, of a minimum width of 200 mm (except number 1 and letter I), of a minimum thickness of 45 mm and of a minimum height of 300 mm. Other dimensions and indications regarding letters and numbers are specified in RRS Appendix G.1.2 (b).

(7) All numbers, letters and the emblem shall be of paint or other, securely attached durable material.

(8) Additional identification for sub-categories within a fleet may be prescribed when so required by a Notice of Race.

#### **C.10.3. (b) USE**

(1) The **sail** shall be hoisted on a **halyard**. The arrangement shall permit hoisting and lowering of the **sail** while afloat with the **boat** upright.

(2) The **sail** shall be set so that the aftmost visible part of the **leech**, projected at 90° to the **boom**, is at or forward of the **outer point**. This changes ERS B.1.3.

(3) **Luff** and **foot** bolt ropes shall be in the respective **spar** grooves or tracks.

#### **C.10.4 JIB**

##### **(a) USE**

(1) The **sail** shall be hoisted on a **halyard**. The arrangement shall permit hoisting and lowering of the **sail** while afloat with the boat upright.

(2) Only one steel luff wire of minimum diameter of 2 mm shall be fitted inside the jib luff sleeve.

#### **C.10.5 SPINNAKER**

**(a) IDENTIFICATION**

Identification shall comply with RRS, except where mentioned hereunder:

As an alteration to RRS Appendix G 1.3 (c), national letters are optional at World and Continental or other ICA sanctioned events. National letters and numbers are optional at national events.

If positioned, national letters may be in line with the sail numbers. The colour of letters and numbers is optional, but they shall be all of the same colour, fully painted, and shall contrast with the colour of the panel to which they are positioned, of a minimum width of 200 mm (except number 1 and letter I), of a minimum thickness of 45 mm and of a minimum height of 300 mm. Other dimensions and indications regarding letters and numbers are specified in RRS.

All numbers and letters shall be of paint or other, securely attached, durable material. Numbers and letters, if on both sides, shall not overlap and shall be placed at different heights with a minimum space of 60 mm.

**(b) USE**

The **sail** shall be hoisted on a **halyard**. The arrangement shall permit hoisting and lowering of the **sail** while afloat with the **boat** upright.

## Section D – HULL AND DECK

### D.1 CERTIFICATION

**D.1.1** The **hull**, before leaving the builder's premises, shall be measured by a **certification measurer** who shall sign the declaration on the IMF that it complies with the **class rules**, lines plan and building specification (Drawing 5). Measurements to ensure the conformity of the **hull** are specified on the IMF but the intention is that beyond these measurements, the **hull** shall completely conform to the Official Documents.

**D.1.2** To be **certified** in conformity with the **class rules**, Lines Plan and Building specification (Drawing N° 5) the **hull** shall comply with the official documents in force at the time of initial **certification control** but all fittings shall comply with the current rules.

**D.1.3** Templates used for **certification control** of **hull** shall be approved by WS.

**D.1.4** Tolerances are only given to allow minor building errors and shall not be deliberately used to alter the design. The **certification measurer** shall report on the IMF what he considers being a departure from the intended nature and design of the **hull**, and the measurement **certificate** may be refused.

**D.1.5** No **hull** shall leave the builders' premises without the ICA plaque and the builder's plaque affixed. The builder's Plaque shall mention:

- The trade mark of the **hull**
- The name of the builder
- The mould number for **hulls** certified after 1<sup>st</sup> January 2015
- The year of building.

The ICA plaque shall mention:

- The WS logo
- The ICA logo
- The sail number allocated to the **boat**

The ICA plaque shall be affixed on the starboard side tank, close to the transom and the builder's plaque on the inside transom (see also rules B.4 and B.5)

### D.2 BUILDERS

**D.2.1** International 420 **hulls** shall be moulded and assembled only by licensed builders. Application for a licence shall be made to WS which shall consult with the ICA and the MNA of the country where the builder has its yard, before granting a license. **Hulls** shall be supplied only as permanently assembled boat units. **Fittings** may be produced by any manufacturer

**D.2.2** Licensed builders have the sole responsibility that their production moulds, plugs and assembled **boats** comply with the relevant **class rules** and official documents.

**D.2.3** If a builder does not comply with the requirements quoted in the **class rules** and the Official documents, WS may revoke the license on the recommendation of the ICA.

**D.2.4** If a builder is found to have supplied a **boat** that does not comply with the rules in application, he shall be liable to rectify the error, and may have his license as a builder withdrawn.

### D.3 BUILDING AND MATERIALS FOR BUILDING

**D.3.1** The **hull** shall be built in conformity with the building specifications (Drawing N° 5)

**D.3.2** Materials used for building shall be those specified on the Building specification (Drawing N° 5). All boats from any one builder shall be built to the same detailed specification submitted by the builder to WS. Any subsequent modifications have to be approved by WS before implementation.

**D.3.3** No less than 0.05 m<sup>3</sup> of positive buoyancy shall be securely attached in each side tank to give approximately equal buoyancy laterally and longitudinally. The buoyancy shall be of closed cell rigid foam, or alternatively of air containers of not less than two litres each. It shall not be used as **hull** reinforcement.

**D.4 ASSEMBLED HULL**

**D.4.1 DIMENSIONS AND MEASUREMENT**

(a) The **hull datum point** (HDP) is the intersection on the hull centre plane of the transom external surface with the underside of the hull surface, both extended as necessary. The aft measuring point (AMP) is the projection of the HDP on the baseline.

(b) For **certification control** of **hulls** built after the 1<sup>st</sup> July 2007, the base line shall be set at 200 mm below the HDP and 92 mm below the keel at 3780 mm from the HDP. All measurements carried out from the HDP shall be made parallel to the baseline and depth measurements perpendicular to the base line. Measurement sections shall be perpendicular to the base line. Hulls built before July 1<sup>st</sup> 2007 shall be controlled using either this arrangement or the baseline arrangement in force at the time of construction.

(c) The **hull length** shall be minimum 4180 mm and maximum 4220 mm.

(d) Measurement sections 1 to 10 shall be at the following positions from the HDP:

- Section 1: at 380 mm from HDP.
- Section 2: at 780 mm from HDP.
- Section 3: at 1180 mm from HDP.
- Section 4: at 1580 mm from HDP.
- Section 5: at 1980 mm from HDP.
- Section 6: at 2380 mm from HDP.
- Section 7: at 2780 mm from HDP.
- Section 8: at 3180 mm from HDP.
- Section 9: at 3580 mm from HDP.
- Section 10: at 3980 mm from HDP.

Vertical distance from baseline to underside of hull shell;	Minimum	Maximum
at section 1	154 mm	170 mm
at section 2	116 mm	132 mm
at section 3	84 mm	100 mm
at section 4	55 mm	71 mm
at section 5	34 mm	50 mm
at section 6	20 mm	36 mm
at section 7	15 mm	31 mm
at section 8	24 mm	40 mm
at section 9	56 mm	72 mm
at section 10	129 mm	145 mm

(e) **Certification Control** of boats shall be performed at sections 2, 5, 8, 9 & 10. If the measurer is in doubt regarding the conformity of the **hull** to the lines plan, the **hull** may be checked at all measurement sections. Prototype measurement for mould approval shall be performed at all 10 stations.

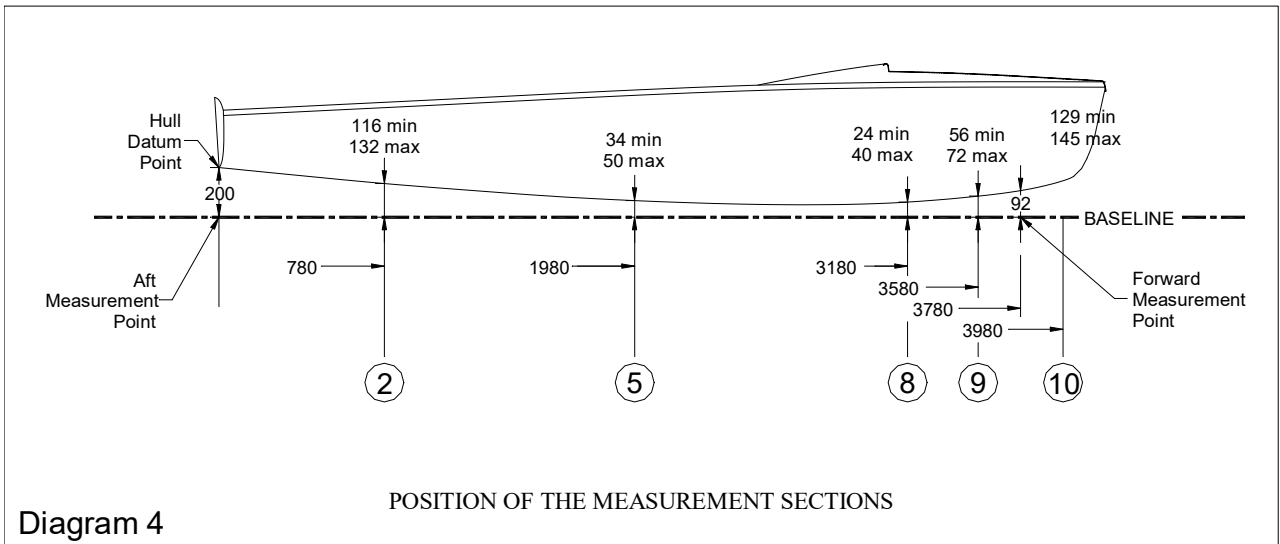

(f) Section templates shall be applied as shown on diagrams 5 and 6. The top of the deck at the sheerline as defined in the building specification shall be not more than 10 mm above or below the sheerline marks on the templates. The gunwale shall touch the templates or clear by a maximum of 50 mm. Below line 1, the templates shall touch the hull or clear by not more than 16 mm, and the difference between the greatest and smallest clearance shall not exceed 12 mm.

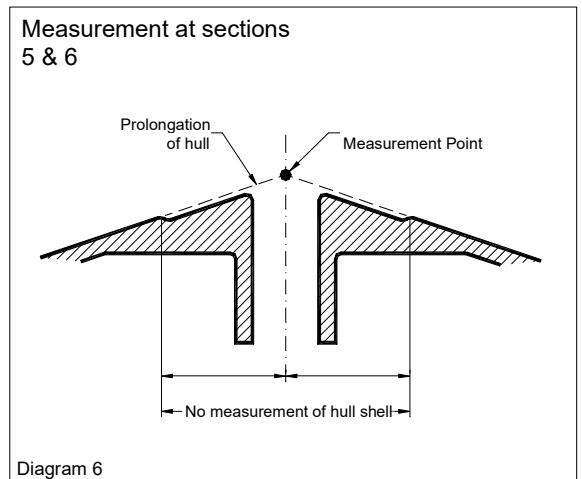
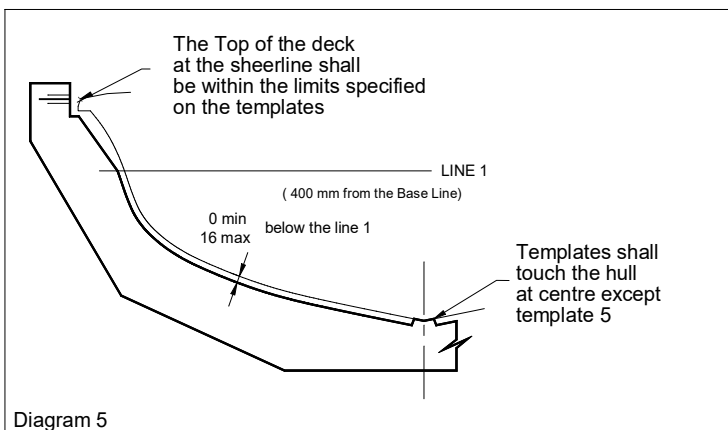

g) The stem template shall be applied as shown on measurement diagram 7. The template shall touch the stem or clear by not more than 15 mm.

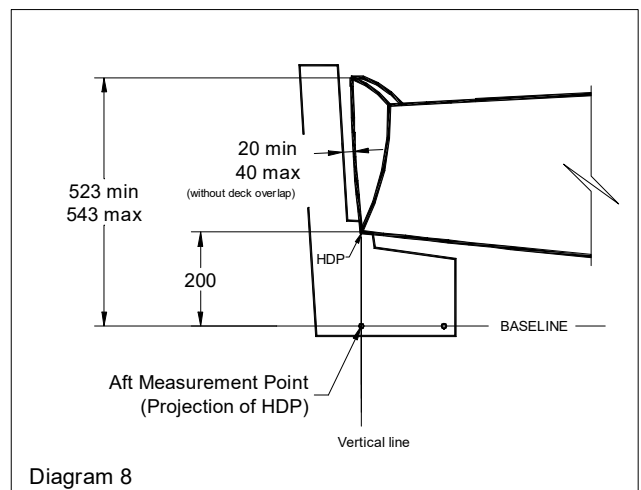
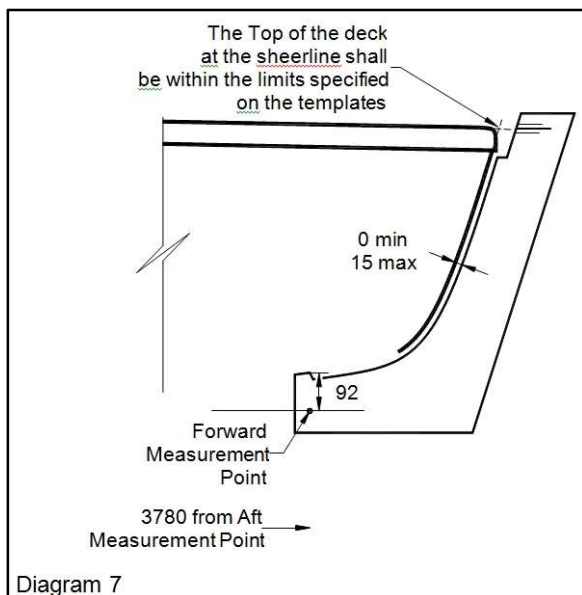



(h) The transom template shall be applied as shown on measurement diagram 8. The distance between the transom and the template shall be minimum 20 mm and maximum 40 mm except at the deck overlap.

(i) The transom radius shall be checked in a horizontal plan located 400 mm above the baseline. On each side, the curvature measured at 520 mm from the centreline shall be 26 mm minimum and 42 mm maximum (see measurement diagrams 9 and 10).

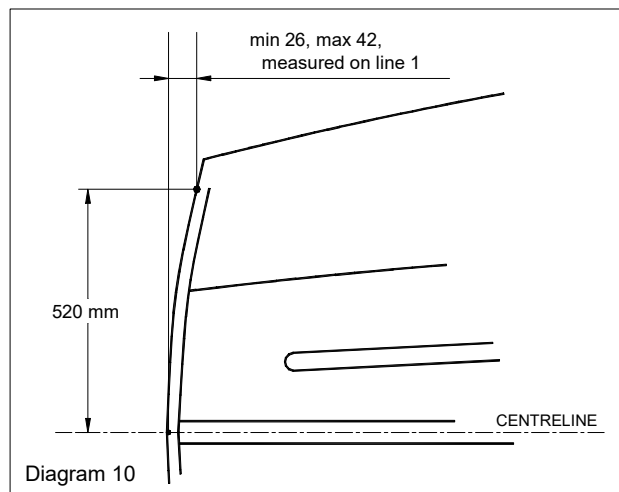
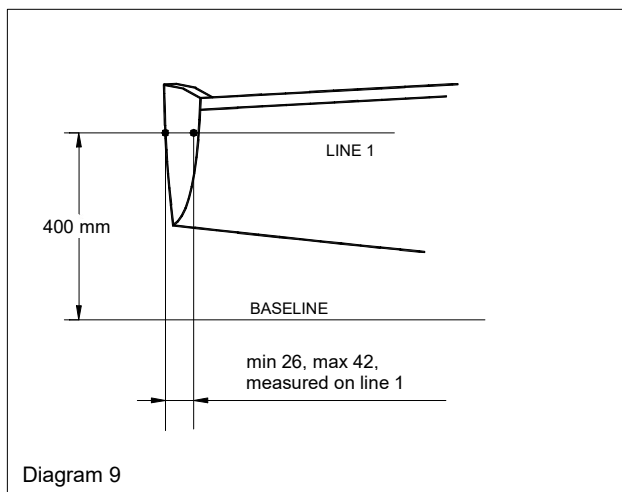

(j) The **centreboard** case shall be in position as shown on measurement diagram 11 and the Drawing N° 5. The forward upper part of the **centreboard** case shall be 330 mm minimum above the underside of the **hull**, and the aft upper part shall be 295 mm minimum above the underside of the **hull**. Overall, the **centreboard** capping width shall be a maximum of 170 mm.

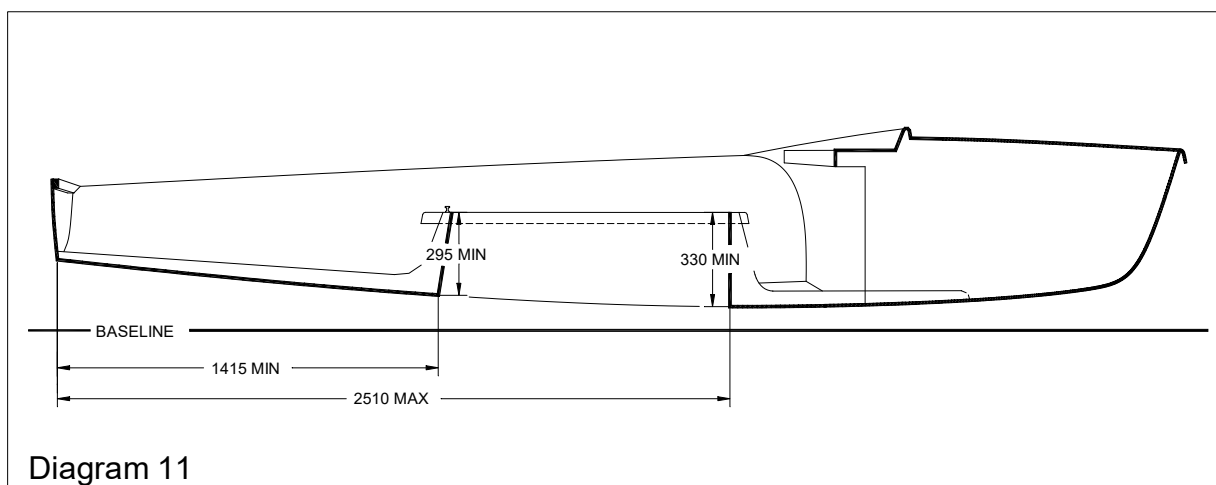

(k) The **hull** shall conform to all the dimensions specified on the drawing N° 5.

(m) The convex curve of the foredeck shall be measured by placing a 300 mm straight edge on any part of the deck forward of the breakwater. In any plane the straight edge shall not be flat against the surface of the deck.

#### D.4.2 ASSEMBLED HULL FITTINGS

*The fittings listed hereunder shall be fitted and used only as specified. Cleats mentioned in these rules, may incorporate a hook or an over-cleat fairlead. A cleat wedge under each cleat is permitted. Except when specified, the direction of the control lines, sheets and ropes shall*

not be modified by means of shackles, rings, loops or holes in the **boat**. Control lines, ropes, sheets, halyards shall not pass through the buoyancy tanks and/or the breakwater. No fittings, with the exception of: spinnaker sheet catcher(s), non-slip material on the gunwale, rudder fittings and transom drainage flaps shall project beyond the outboard edges of the gunwale or beyond the profile of the **hull**.

No fitting shall serve as an extension of the hull surface.

**Ballast** other than **corrector weights** shall not be carried.

Materials for permitted fittings are optional except that Titanium is prohibited.

#### D.4.2. (a) MANDATORY, WITH POSITION OR DIMENSION SPECIFIED

The following fittings shall be positioned in accordance with the drawing N° 5 and shall be used as specified

- (1) One stem-head fitting for attachment of the forestay and the headsail. The centre of the front hole of the stem-head fitting shall be at 4085 mm minimum and 4125 mm maximum from the HDP. Only one hole for the forestay and one hole for the jib are permitted. The forestay shall be attached to the front hole and the jib shall be attached to the aft hole.
- (2) Two shroud plates for the shrouds, one for each side of the boat. The centre of the hole of the shroud plates measured on the centreline shall be at 2550 mm minimum and 2570 mm maximum from the HDP.
- (3) One mainsheet track or bar of any profile, made only of metal or GRP. It shall be straight and fixed to the centreboard case capping. The track or bar shall have a maximum height of 40 mm and a maximum width of 40 mm. The centreline of the track or bar shall be fixed to the side tanks at 1400 mm minimum and 1500 mm maximum from the HDP.
- (4) One mast step fixed on the keelson. The length of the mast step shall be 150 mm maximum. The forward end of the mast step shall be at 2890 mm minimum and 2910 mm maximum from the HDP. The bearing surface of the mast step shall be at 5 mm maximum from the top surface of the keelson.
- (5) Two jib fairleads, the measurement point of which shall be at 2020 mm minimum and 2120 mm maximum from the HDP and 625 mm minimum from the centreplane. The fairleads shall be fixed directly to the buoyancy tanks (see diagram 12).

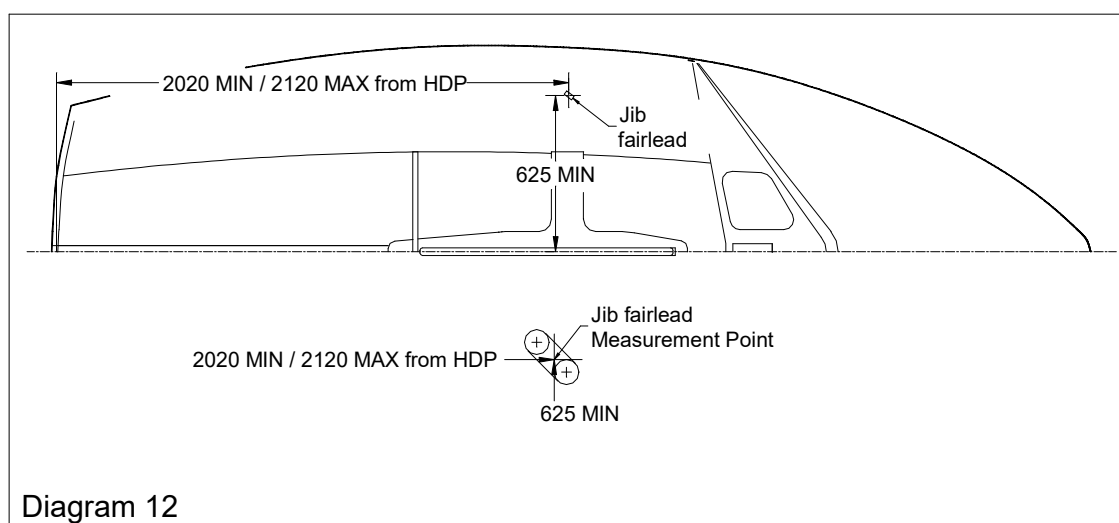

Diagram 12

- (6) One drain hole in each buoyancy tank, located near the transom, with a diameter of 15 mm minimum and 25 mm maximum
- (7) A minimum of one inspection hole for each buoyancy tank with a minimum diameter of 100 mm.

- (8) Two spinnaker bags located according to Drawing 5.
- (9) A minimum of one draining hole or port in the transom, with a maximum total area of 80 cm<sup>2</sup>. Hinged covers or other devices for closing draining ports or drain holes in the transom. These covers or devices shall not obstruct the rudder

**(b) MANDATORY, WITH POSITION OR DIMENSION OPTIONAL**

- (1) One block fixed to a mounting on the aft part of the centreboard case capping or the keelson for the mainsheet. (See also Rule F.6.2(a)(5))
- (2) One cleat without moving parts and one guiding block directly behind the cleat for the kicking strap system.
- (3) Two rudder fittings (pintles or gudgeons) for the **rudder**.
- (4) One swivelling cleat with moving parts fixed on the aft part or the centreboard case capping or two cleats with moving parts on the side tanks for the mainsheet.
- (5) Two cleats with moving parts, fixed on the side tanks, for the jib sheets.
- (6) Two cleats with or without moving parts, fixed on the side tanks, for the spinnaker sheets.
- (7) One fairlead and one cleat with or without moving parts for the spinnaker halyard.
- (8) One cleat without moving parts and one guiding block directly behind the cleat for the spinnaker uphaul/downhaul system (adjusting the height of the **spinnaker pole**). An additional block, a rope and a device to attach the rope is permitted between the **mast** and the cleat mentioned above. One fairlead at the mast partner for the spinnaker pole downhaul rope. **Mast** fittings for the **spinnaker pole** uphaul/downhaul are specified in F 2.4(q).
- (9) A maximum of six fairleads (also mentioned in F.5.1(b)) for the elastic cord of the two **trapeze** lines.
- (10) Two spinnaker fairleads or blocks for the spinnaker sheets.
- (11) A centreboard pin with optional bushing and washers.

**(c) OPTIONAL**

The following fittings -if fitted- shall be used only as specified below:

- (1) One self-bailer
- (2) Toe straps inside the cockpit area for the **crew**, adjustable by means of ropes and knots or one cleat without moving parts, and elastic cord to keep them lifted up.
- (3) Spinnaker catcher fitting(s) which shall not project outside the gunwale edges or more than 150 mm beyond the bow.
- (4) One hook on each side of the **hull**, on shrouds/shroud plates or fixed on the deck and at 100 mm maximum forward of the centre of the hole of the shroud plates, to lead the **spinnaker guy** aft.
- (5) Devices for securing the spinnaker halyard while the spinnaker is not set
- (6) Tubular covers at the lower end of **shrouds** or their adjusters and the lower end of the **forestay** to ease the passage of the sheets and to prevent snagging.
- (7) Stainless steel springs under blocks to prevent them from falling over.
- (8) One non-electrical wind indicator at the **mast** head.

- (9) Sealing strips for the centreboard case slot of optional material.
- (10) Strips of a minimum length of 300 mm and maximum width of 30 mm to reduce friction and/or the distance between the centreboard and centreboard case, but no device shall be attached to the inside of the centreboard case that could cause the centreboard to gybe (angle to windward).
- (11) A moulded insert in the thwart or a device to secure the **spinnaker pole** in the cockpit.
- (12) Jib tack adjustment system, consisting of a shackle on the stemhead fitting, one cleat without moving parts mounted on the foredeck, one fairlead directly behind the cleat and a rope.
- (13) One Cunningham control system of rope with a maximum of two single-sheave blocks. One cleat without moving parts and one guiding block directly behind the cleat for the mainsail Cunningham line on the centerboard case capping.

#### **D.5 HULL WEIGHT**

The **hull weight**, including stem head fitting, shroud plates without shroud adjusters, all fixed fittings, complete hiking straps, rudder pintles or gudgeons, self-bailer, mainsheet track/bar, **centreboard** pivot pin, inspection port covers, spinnaker bags and **corrector weights**, but excluding the control lines, sheets and **portable equipment** shall be 80 kg minimum in dry condition.

#### **D.6 HULL CORRECTOR WEIGHTS**

If the **hull weight** according to D.5 is found to be less than 80 kg, **corrector weights** of a maximum total weight of 2 kg shall be bolted to the upper inside surface of the transom. The number and total weight of correctors shall be recorded on the IMF and the measurement **certificate**. **Corrector weights** shall not be removed or altered without the **hull** being re-weighted by a **certification measurer**.

## Section E - CENTREBOARD, RUDDER AND TILLER

### E.1 RULES

Centreboard and rudder shall comply with the current class rules.

### E.2 MANUFACTURERS

The manufacturer is optional.

### E.3 CENTREBOARD

**E.3.1** The **centreboard** shall be of even thickness, minimum 16 mm and maximum 20 mm throughout, except that it may be bevelled to a maximum distance of 105 mm from the edges. Except for permitted bevelling, the thickness shall not vary by more than 1 mm.

**E.3.2** The **centreboard** shall be made from one or a combination of the following materials; wood, plywood, polyester resin reinforced with glass fibre, epoxy reinforced with glass fibre and/or plastic foam which includes micro-balloons, and may be painted.

**E.3.3** The profile of the **centreboard** shall conform to the dimensions and tolerances specified on the measurement diagrams 13 & 14.

Lines (OA) and (OE) build the reference axes for length and width respectively, and shall be square to each other. Point (O) is the origin for both axes.

The profile of the **centreboard** is defined by the points A, origin O, E, G, the lines (GH) and (AI)

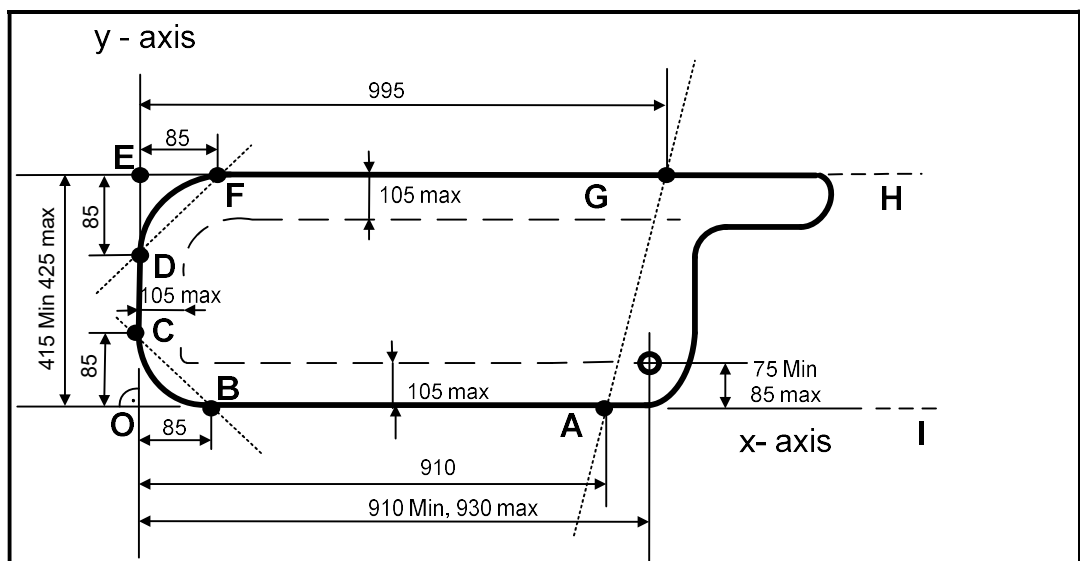

Diagram 13

Point A is on the X axis, 910 mm from origin.

Point B is on the X axis, 85 mm from origin.

Point C is on the Y axis, 85 mm from origin.

The centreboard shall always touch points A, B and C, which are integral to it.

Point F is the point on the trailing edge 85 mm from axis Y.

Point G is on the trailing edge at 995 mm from Y axis.

Point E is the extension of the trailing edge (FG) on the Y axis.

Point D is the point on the lower edge 85 mm from point E, measured along axis Y. It shall be not more than 2mm from axis Y.

The trailing edge (FG) is parallel to the x-axis: the distance of point (G) from the outmost point of the leading edge, measured along y-axis, shall be equal to width (OE) within 2

mm. At no point the width of the **centreboard** shall be more than 425 mm or less than 415 mm.

	minimum	maximum
Distance from the centre of the pivot hole to the x-axis	75 mm	85 mm
Distance from the centre of the pivot hole to the y-axis	910 mm	930 mm
Distance from E to the x-axis	415 mm	425 mm
Total (positive, negative or both) deviation of an edge from a straight line:		
Between points A and B from the x-axis.....		2 mm
Between points C and D from line (CD) .....		2 mm
Between points F and G from line (FG).....		2 mm

Point I is on the X-axis. Lines (AI) and (GH) are parallel. The profile of the **centreboard** inside area HGAI is free, but no part of it shall lay outside this area.

The shape of the lower corners of the **centreboard** shall lie within the shaded areas in diagram 14, and no part of the bottom edge of the **centreboard** shall lie outside the polygon formed between points B, B', C', D', F' and F.  
 Point B' is the point on the x-axis 45 mm from origin O.  
 Point C' is the point on the y-axis 45 mm from origin O.  
 Point D' is the point on the y-axis 45 mm from point E.  
 Point F' is the point on line (EG), 45 mm from point E.

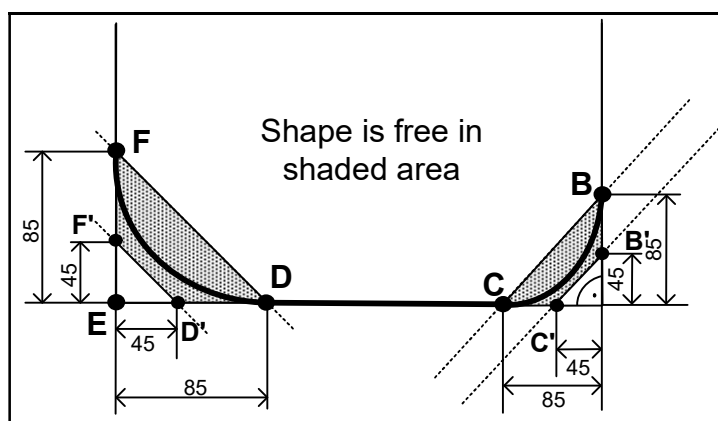

Diagram 14

**E.3.4** Only the following fittings are permitted:

(a) One **centreboard** uphaul of rope and/or elastic using a maximum of three single-sheave blocks and two cleats without moving parts. A cleat wedge is permitted under each cleat, and a fairlead in front of/ or integral to the cleat.

(b) One **centreboard** downhaul of rope and elastic, one fairlead and/or one block. One cleat without moving parts on the centreboard case capping. A wedge is permitted under the cleat.

**E.3.5** The direction of the control lines used for the adjustment of the **centreboard** shall be modified only by means of the blocks specified in E.3.4(a) and fairlead and block specified in rule E.3.4(b).

**E.4 RUDDER**

**E.4.1** The profile of the **rudder** blade shall conform to the dimensions and tolerances

specified on the Diagram 15 (same as the official 420 **rudder** blade drawing - August 2000)

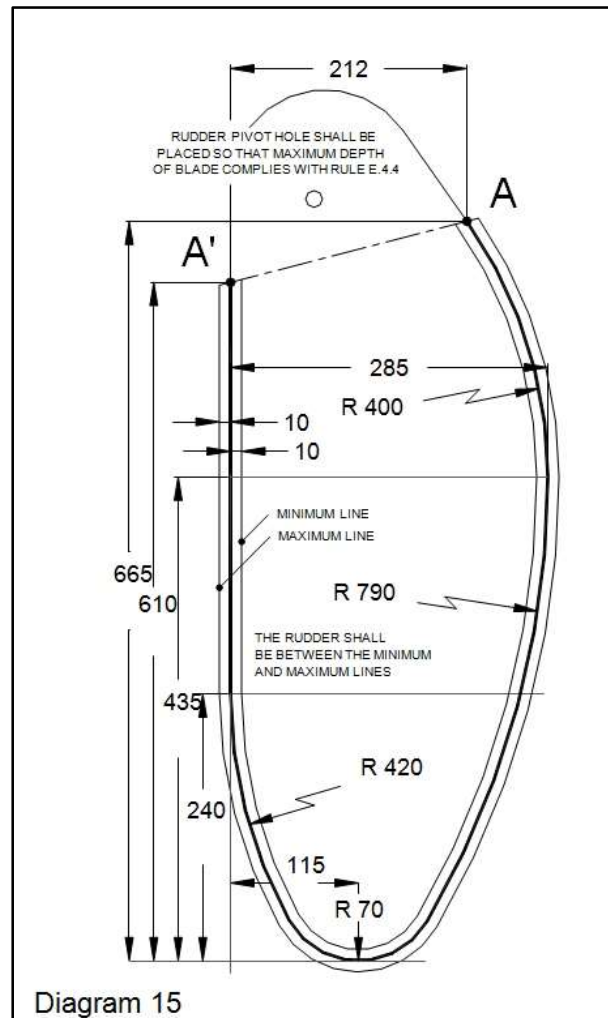

- E.4.2** The **rudder** blade shall be of even thickness, minimum 16 mm and maximum 20 mm throughout, except that it may be bevelled to a maximum distance of 105 mm from the edges. Except for permitted bevelling, the thickness shall not vary by more than 1 mm.
- E.4.3** The **rudder** stock shall be made of aluminium alloy and/or stainless steel and the tiller of wood or aluminium alloy. Strips of any material may be added to reduce friction and/or the distance between the **rudder** stock and **rudder** blade. The **rudder** stock shall not act as an extension of the hull. The **rudder** blade shall be made of one or a combination of the following materials; wood, plywood, polyester with glass fibre, epoxy with glass fibre and/or plastic foam, which includes micro-balloons and may be painted.
- E.4.4** Only the following fittings are permitted:
- One **rudder** downhaul made of one stainless steel wire and/or rope and elastic and one cleat without moving parts on the tiller (a wedge under the cleat is permitted), or a safety pin or bolt through the **rudder** head and **rudder** blade to fix the **rudder** blade position.
  - One tiller extension, which may be telescopic and of any material.
  - One universal joint between tiller and extension.
  - One rudder pivot pin.
- E.4.5** A safety device shall be fitted so that the **rudder** stock cannot separate from the **hull** if the boat capsizes.

## Section F - RIG

### F.1 RULES

Rigs shall comply with the current class rules.

### F.2 MAST

#### F.2.1 MANUFACTURER

Manufacturer is optional.

#### F.2.2 MATERIALS

The **mast spar** shall be of aluminium alloy. It may be anodised or painted.

#### F.2.3 CONSTRUCTION

The **mast** shall include a fixed sail groove or track, which may or may not be integral to the **spar** but shall be of aluminium. Rotating and permanently bent **masts** are prohibited but a **mast spar curvature** measured at any place of the **mast** between the **upper** and **lower points**, of a maximum of 40 mm is permitted.

#### F.2.4 FITTINGS

The following fittings are mandatory and shall be used as specified:

(a) A **mast** head fitting which may include the upper sheave for the mainsail halyard.

(b) The direction of the halyards shall be modified only by means of the blocks, sheaves or fairleads specified in Section F of the **class rules**, except that the mainsail halyard may turn through the halyard shackle on the **mainsail head** to form a 2:1 purchase.

(c) One lock near the masthead or one lock, cleat or tooth rack below the gooseneck for the mainsail halyard.

(d) A maximum of two blocks, sheaves, or fairleads for each halyard (mainsail, jib, spinnaker). These blocks or sheaves shall be fixed on the **spar**.

(e) The upper jib halyard sheave, block or fairlead shall be positioned so that the **headsail hoist height** is less or equal to the **forestay height**

(f) No part of the upper spinnaker halyard sheave, block or fairlead shall project more than 40 mm from the foreside of the **mast**.

(g) The positions of **rigging points** of the **shrouds**, **forestay** and **trapeze** lines shall be at the distances mentioned in F.2.5 (see **shrouds**, **forestay** and trapeze heights).

(h) A pair of fixed or adjustable metal **spreaders**, with optional attachment systems. The **spreader height** shall be at the distance stated in F.2.7. Optional devices may be attached to the spreaders and/or the rigging to prevent the spinnaker halyard from getting tangled.

(i) One **spinnaker pole fitting** on the foreside of the **mast**, with a maximum **projection** of 45mm.

(k) One gooseneck, fixed to the **mast** to connect the **boom** to the **mast**.

(m) One cleat without moving parts below the gooseneck and one rope, for the mainsail Cunningham line if the system in D.4.2(c)(13) is not present.

(n) A tensioning system for the jib halyard made of two blocks with a maximum of six sheaves in total, and one cleat. This cleat may have moving parts and shall be fixed at one of the two blocks. The system shall be attached via a hook or a shackle to the jib halyard, and at the other end to the **mast** or the mast step fitting, by means of a wire strop or shackles and an attachment to the **mast** (tang, mast anchor plate etc).

(o) One rope or a device around the **mast** and through the mainsail **tack** cringle to secure the mainsail **tack**.



- (p) A protection device around the **mast** at the **mast** gate
- (q) One **spinnaker pole** uphaul / downhaul made of rope and elastic and one hook. The **spinnaker pole** uphaul / downhaul may be fitted with two plastic balls. For the adjustment of the **spinnaker pole** uphaul / downhaul, only the following fitting is permitted, one eye or block on the foreside of the **mast**, located below the forestay and shroud **rigging points**. One eye or block or fairlead on the foreside of the **mast** at the level of the mast partner. Two blocks, sheaves, or fairleads at the bottom of the **mast**. (Additional fittings for the **spinnaker pole** uphaul/downhaul are stated in D.4.2(b)(10)).
- (r) One **vang** (Kicking strap) attachment fitting
- (s) A **mast** heel fitting which may include the lower sheaves for the halyards and **spinnaker pole** uphaul / downhaul.
- (t) Permanently painted / taped **limit marks** in a contrasting colour.
- (u) A device for preventing the mainsail from being set above the **upper point**, to ensure compliance with C.10.3(b)(2), unless the mainsail halyard is set on a lock or tooth rack as in F.2.4(c). Rivets in the sail track are not compliant devices.

## F.2.5 DIMENSIONS

Unless otherwise specified, all longitudinal measurements shall be carried out from the **mast datum point**. For this purpose, the **mast datum point** (MDP) is located at the **mast heel point**.

	minimum	maximum
<b>Mast length</b>		6260 mm
Fore and aft <b>mast spar cross section</b> between 1550 mm and 4500 mm from the MDP	50 mm	75 mm
Transverse <b>mast spar cross section</b> within 4500 mm from MDP	45 mm	75 mm
<b>Mast limit marks width</b>	10 mm	
<b>Lower point height</b>		1160 mm
<b>Mainsail luff mast distance</b>		4900 mm
<b>Headsail Hoist Height</b>	4520 mm	actual <b>forestay height</b>
<b>Spinnaker hoist height</b>		4650 mm
<b>Shrouds, forestay and trapeze heights</b>	4550 mm	4650 mm
<b>Spreader height</b>	2550 mm	2650 mm

## F.2.6 WEIGHT

The **mast weight**, with fittings specified in F.2.4 but without the tensioning system mentioned in F.2.4(n) and the rope mentioned in F.2.4.(o), and including fittings specified in F.5.1 without the elastic cord and the four fairleads stated in F.5.1(b) and with the length of elastic at the level of the **spreaders** as stated in F.5.1(b), shall be minimum 7.5 kg.

**F.2.7** The centre of gravity of the **mast**, including fittings and **rigging** listed in F.2.6 with the **shrouds, forestay, trapeze** lines and halyards secured along the **mast**, shall be at 2400 mm minimum from the **mast datum point**. For the measurement, the halyards shall be hoisted and the halyard tails outside the **mast** shall be kept in hand by the measurer.

## F.3 BOOM

### F.3.1 MANUFACTURER

Manufacturer is optional.

### F.3.2 MATERIALS

The **boom spar** shall be of aluminium alloy. It may be anodised or painted.

### F.3.3 CONSTRUCTION

- (a) The **boom** shall include a fixed aluminium sail groove or track, which may or may not be integral to the **boom spar**.
- (b) The **boom spar** shall be of the same cross section throughout and shall not be tapered.

### F.3.4 FITTINGS

#### (a) MANDATORY

- (1) A **vang** (Kicking strap) attachment (eye, plate, or hole through the **boom**)
- (2) Two mainsheet block attachments (eyes, plates, or holes through the **boom**)
- (3) A gooseneck attachment / front end fitting
- (4) One aft end fitting which may incorporate one sheave; one outhaul consisting of rope, a maximum of one block, one cleat without moving parts and optional elastic cord; a guiding block for the cleat may be used. The outhaul rope may pass through the mainsail clew cringle and terminate on the aft end fitting.
- (5) A device for preventing the mainsail from being set outside the **outer point**, to ensure compliance with C.10.3(b)2. Rivets in the sail track are not compliant devices.
- (6) Permanently painted / taped **outer limit mark** in a contrasting colour.

#### (b) OPTIONAL

- (1) Ropes or devices through the cringles and around the **boom** to secure the **mainsail** at the clew and the tack.
- (2) Protective devices where the **boom** touches the **shrouds**, of any material (maximum length / height / thickness = 100 mm / 50 mm / 5 mm)

### F.3.5 DIMENSIONS

	minimum	maximum
Vertical <b>boom spar cross section</b>	55 mm	89 mm
Transverse <b>boom spar cross section</b>	32 mm	76 mm
<b>Boom limit mark width</b>	10 mm	
<b>Outer point distance</b>		2400 mm

### F.4 SPINNAKER POLE

#### F.4.1 MANUFACTURER

Manufacturer is optional

#### F.4.2 MATERIALS

The **spinnaker pole spar** shall be made of aluminium alloy. It may be anodised or painted.

#### F.4.3 FITTINGS

Only the following fittings are permitted:

- (a) End fittings and control line which may incorporate knots, toggles or short tubes for easier handling.
- (b) Fittings approximately at the midpoint for attachment for uphaul/downhaul.

#### F.4.4 DIMENSIONS

The maximum **spinnaker pole length** is 1750 mm.

## F.5 RIGGING AND FITTINGS

### F.5.1 RIGGING

The standing **rigging** shall comply with the current **class rules**. **Certification** is not required. The following **rigging** shall be used, and consist of only:

(a) A **forestay** and one **shroud** on each side, to support the **mast**. These shall be of steel wire rope with a minimum diameter of 2 mm. Rod rigging is prohibited.

(b) One **trapeze** line, with a minimum diameter of 2 mm, on each side for the use of one person only. The material of the **trapeze** line is optional. Each **trapeze** adjustment system shall be provided with a maximum of one handhold, two sheaves, a ring or hook, an elastic cord, one rope, and one cleat. The two **trapezes** shall be connected to the **hull** by elastic cord with a maximum of six fairleads as stated in D.4.2.b).(10). Elastic is permitted to keep each **trapeze** line clear of the **spreaders** and **shrouds**. Self-tacking **trapeze** systems are not permitted.

### F.5.2 FITTINGS

(a) Each **shroud** shall be attached to the shroud plates by means of plates having rows of adjustment holes and pins. No other method of shroud adjustment is permitted.

## F.6 RUNNING RIGGING

### F.6.1 MATERIALS

(a) Materials are optional.

### F.6.2 PARTS

#### (a) MANDATORY

(1) Mainsail halyard (See F.2.4(b))

(2) Headsail halyard (See F.2.4(n))

(3) Spinnaker halyard, the tail of which may be attached to an elastic rope (See D.4.2(b)(7) and D.4.2(c)(5))

(4) Spinnaker pole lift and downhaul (see F.2.4(q) and D.4.2(b)(10))

(5) Mainsail sheet that shall have four single-sheave blocks, one of which may be a ratchet block. The mainsheet shall be attached to the block which is connected to the bridle. Two blocks shall be attached directly to the **boom**. The fourth block shall be fixed to a mounting on the aft part of the centreboard case capping or keelson. The maximum obtained purchase shall be 4:1.

(6) Jib Sheet

(7) Spinnaker Guy and Sheet

(8) A mainsheet bridle made either of:

i) Two strops, either of rope or wire. Each strop shall be attached to a point on the mainsheet bar/track or its end fittings, and to the mainsheet block, so forming a triangle. Each strop may be adjustable by including one additional permanently fixed eyelet and one snap hook/shackle fixed at the track/bar or its end fittings, or

ii) Two strops of rope. The strop of each side shall pass through a sheave or block attached to the end fittings of the mainsheet track/bar, and then end in a cleat without moving parts, fixed on the mainsheet track/bar. One sheave and one cleat per side are the only fittings permitted.

Any other adjustment system is prohibited.

(9) One **vang** (Kicking strap) of rope and/or stainless steel wire with a maximum of five single-sheave blocks.

#### (b) OPTIONAL

- (1) Mainsail Cunningham line (see D.4.2(c)(13))
- (2) Mainsail outhaul (see F.3.4(a)(4))
- (3) Mainsail tack attachment (see F.2.4(o))
- (4) One Jib Tack adjustment system (see D.4.2(c)(12))

## Section G – SAILS

### G.1. MEASUREMENT

- G.1.1 Unless otherwise specified in these rules, **sails** shall comply with the current **class rules**.
- G.1.2 Jibs may be measured with battens inside the **batten pockets**.
- G.1.3 Jib luff wires shall be removed for measurement.

### G.2 CERTIFICATION

- G.2.1 The **certification measurer** shall **certify mainsails** and jibs at the **tack**, and **spinnakers** at the **head**, and shall sign and date the **certification mark**. The **mainsail** and the **spinnaker** may be **certified** without letters and numbers, but they shall comply when *racing* with Class rules C.10.3(a) and C.10.5(a)
- G.2.2 A WS In-House Certification (IHC) Authorizing Authority may appoint one or more **In-House Certification Measurers** at a sailmaker to measure and **certify** sails produced by that manufacturer in accordance with the WS guidelines.
- G.2.3 For the mainsail and jib, the weight in g/m<sup>2</sup> of the **body of the sail** shall be indelibly marked at the **head** by the sailmaker together with the date and his signature or stamp.
- G.2.4 Each sail first **certified** after 1st March 2005 shall have permanently fixed an officially numbered ICA royalty sail button or sticker, located for mainsails and headsails at the **tack** and spinnakers at the **head**. No sail shall be accepted for certification control without a sail button / sticker. Sail buttons / stickers shall not be transferred from a sail to another.

### G.2.4 SAILMAKER

Sailmaker is optional.

### G.3 MAINSAIL

#### G.3.1 EMBLEM

The 420 emblem shall be in dark blue, positioned below and adjacent to the top **batten pocket** and conform to the dimensions and requirements mentioned in the diagram with a tolerance of +/- 2 mm (see diagram 16).

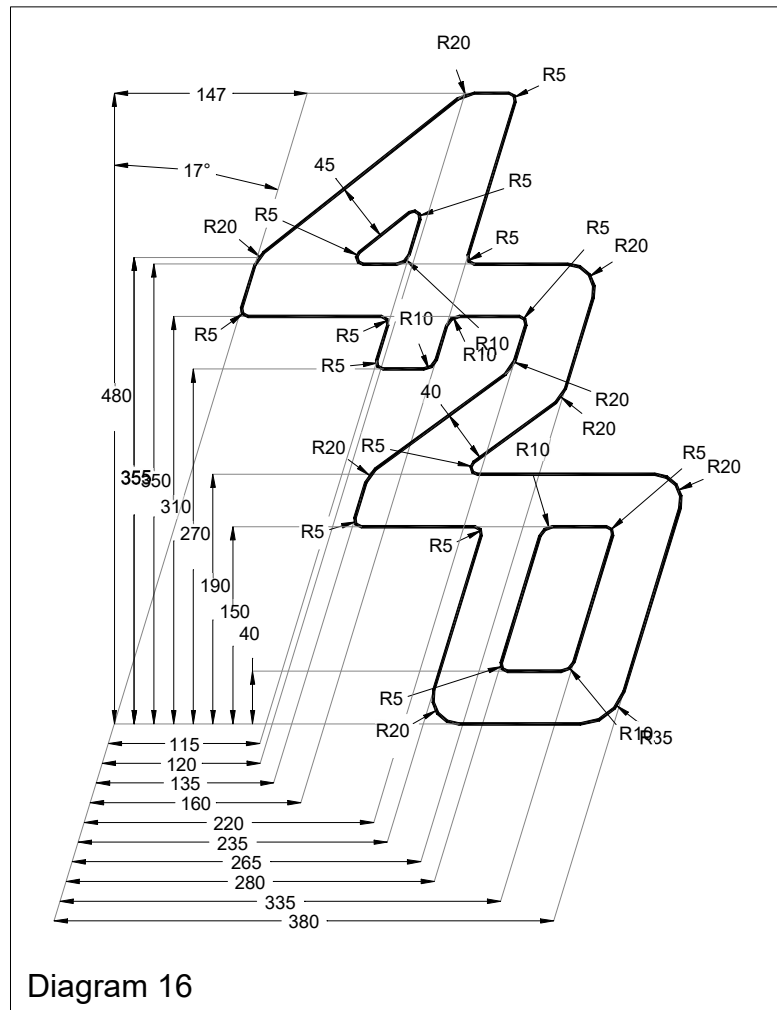

### G.3.2 CONSTRUCTION

(a) The construction shall be: **Soft sail, single-ply sail.**

b) The **body of the sail** shall consist of the same **woven ply** throughout except for the panel adjacent to the **foot**, which may be of a different **woven ply**. This limitation does not apply to the colour of the ply. The **ply** fibres shall be of polyester. **Primary** and **secondary reinforcement** permitted material is woven ply with polyester fibres.

(c) The weight of the **ply** of the **body of the sail** shall be minimum 150 g/m<sup>2</sup>.

(d) The following are permitted:

Stitching, glues, **tabling**, tapes, bolt ropes for the **luff** and the **foot**, one cringle/eye at each **sail corner**, one headboard with fixings, one Cunningham eye, **batten pocket patches**, **batten pocket** associated fittings, one **batten pocket** end cap and one batten tensioning device for the top **batten pocket**, one boom slide at the **clew**, leech line with cleat on leech, sail shape indicator stripes, tell tales, ICA sail button or sticker, sailmaker's trade mark, not more than two **windows**.

(e) The ICA sail button / sticker shall be fixed in the **tack**.

(f) The **leech** shall not extend aft of straight lines between:

- (1) The **aft head point** and the intersection of the **leech** and the upper edge of the nearest **batten pocket**,
- (2) The intersection of the **leech** and the lower edge of a **batten pocket** and the intersection of the **leech** and the upper edge of an adjacent **batten pocket** below,

(3) The **clew point** and the intersection of the **leech** and the lower edge of the nearest **batten pocket**.

(g) The **sail** shall have four **batten pockets** in the **leech**, positioned as in Diagram 17. Positions will be measured with the **leech** flattened by flaking/folding the mainsail.

### G.3.3 DIMENSIONS (SEE DIAGRAM 17)

	<b>Minimum</b>	<b>Maximum</b>
<b>Leech length</b>		5400 mm
<b>Quarter width</b>		2130 mm
<b>Half width</b>		1630 mm
<b>Three-quarter width</b>		995 mm
<b>Upper width at upper leech point</b> (600 mm from the <b>head point</b> )		480 mm
<b>Top Width</b>		115 mm
<b>Flutter patches size</b>		100 mm
<b>Chafing patches size</b>		900 mm
<b>Primary reinforcement at corners</b>		300 mm
<b>Secondary reinforcement at corners</b>		900 mm
<b>Batten pocket patch size</b>		150 mm
Extension of the centreline of the top <b>batten pocket</b> to the <b>luff</b> from the <b>head point</b>	1420 mm	1470 mm
<b>Inside batten pocket length</b> of lowermost		540 mm
<b>Inside batten pocket length</b> of the two intermediate		700 mm
Lowermost batten length		540 mm
Intermediate batten length		700 mm
Inside <b>Batten pocket width</b>		60 mm
Total <b>Window opening Area</b>		0.3 m <sup>2</sup>
Window opening to the <b>sail edge</b>	150 mm	
<b>Foot boltrope length for sails first certified</b> after 1 <sup>st</sup> March 2003	1920 mm	

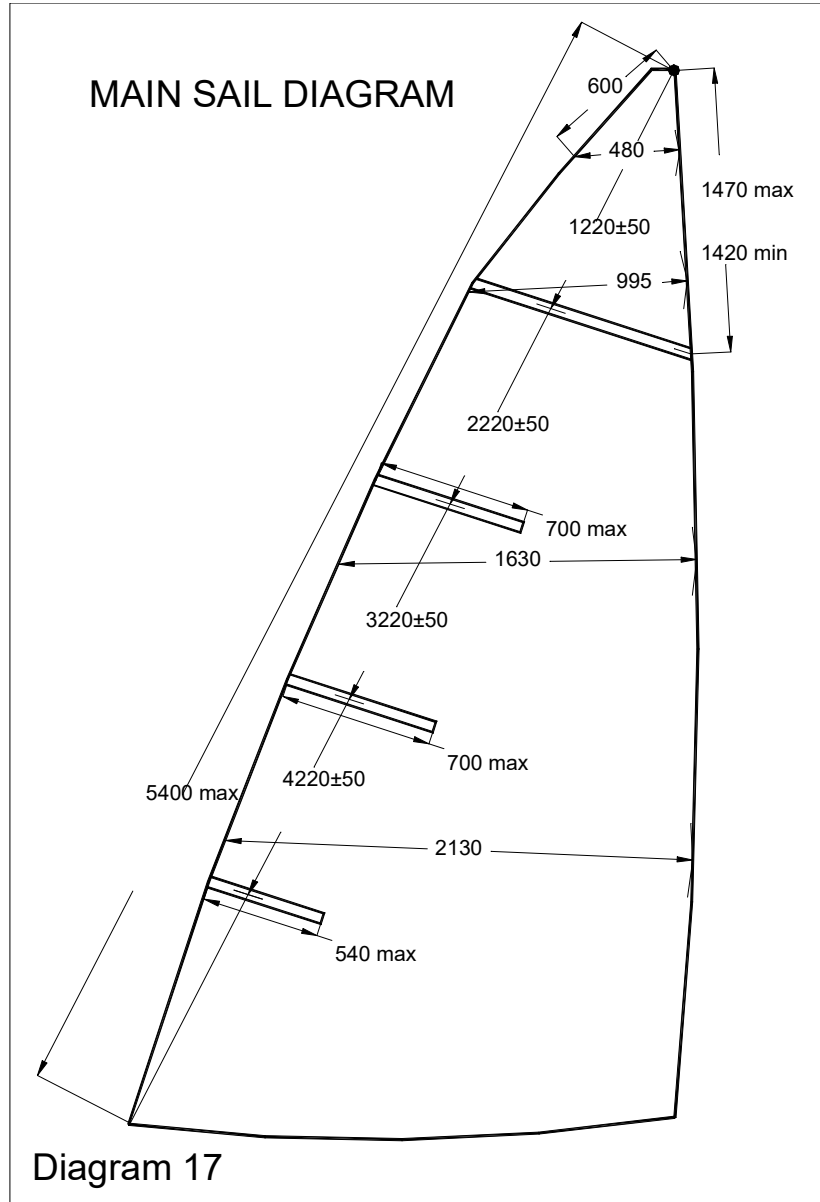

**G.4 JIB**

**G.4.1 CONSTRUCTION**

- (a) The construction shall be: **Soft sail, single-ply sail**. The **leech** shall not extend beyond a straight line between the aft **head point** and the **clew** point (i.e. shall not be convex).
- (b) The **body of the sail** shall consist of the same **woven ply** throughout, this limitation not applying to the colour. The **ply** fibres shall be of polyester. **Primary** and **secondary reinforcement** permitted material is **woven ply** with polyester fibres.
- (c) The weight of the **ply** of the **body of the sail** shall be minimum 150 g/m<sup>2</sup>.
- (d) The jib may have a maximum of three **batten pockets** in the **leech**.
- (e) The following are permitted: Stitching, glues, tapes, **tabling**, one cringle / eye at each **sail corner**, not more than two **windows**, tell tales, a rope for the **luff** tension adjustment and one cleat in the **tack** area, a steel wire rope inside the **luff** sleeve, sail button / sticker, sailmaker's trade mark.
- (f) The sail button / sticker shall be fixed in the **tack**.



(g) Only the following **tack** construction arrangements are permitted for jibs **certified** after January 1<sup>st</sup>, 2017.

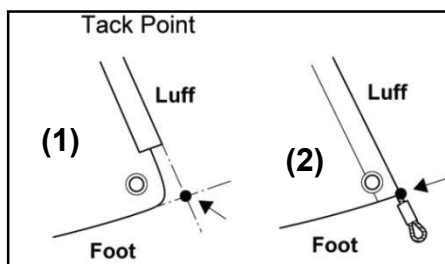

(h) Only the following **clew** construction arrangements are permitted for jibs **certified** after January 1<sup>st</sup>, 2017.

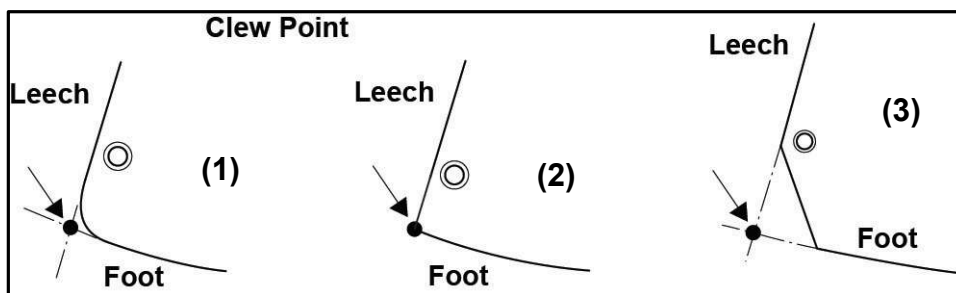

#### G.4.2 DIMENSIONS

	<b>Maximum</b>
<b>Luff length</b>	3500 mm
<b>Leech length</b>	3200 mm
<b>Foot length</b>	1750 mm
<b>Foot median</b>	3360 mm
<b>Top width</b>	40 mm
<b>Foot irregularity</b> for sails first <b>certified</b> after 1st March 2010	30 mm
<b>Flutter patches size</b>	100 mm
<b>Batten pocket inside length</b>	200 mm
<b>Batten pocket patches</b>	150 mm
<b>Chafing patches size</b>	900 mm
<b>Primary reinforcement</b> at corners	300 mm
<b>Secondary reinforcement</b> at corners	900 mm
<b>Total Window opening area</b>	0,1 m <sup>2</sup>
	<b>Minimum</b>
Window opening to the <b>sail edge</b>	150 mm

#### G.5 SPINNAKER

##### G.5.1 CONSTRUCTION

(a) The construction shall be: **Soft sail, single-ply sail**. The **sail** shall be symmetrical about its centreline.

(b) The **body of the sail** shall consist of the same **woven ply** throughout, this limitation not applying to the colour. The **ply** fibres shall be of polyester or polyamide. **Primary** and **secondary reinforcement** permitted material is **woven ply** with polyester or polyamide fibres.

(c) The following are permitted: Stitching, glues, tapes, corner eyes, tell tales, sail button / sticker, sailmaker's mark.

(d) The sail button / sticker shall be fixed in the **head**.

## G.5.2 DIMENSIONS

	<b>Maximum</b>
<b>Leech Length</b>	4000 mm
<b>Foot Length</b>	2220 mm
<b>Half Width</b>	2840 mm
<b>Primary Reinforcement</b> at corners	300 mm
<b>Secondary Reinforcement</b> at corners	900 mm
<b>Foot Median</b> for <b>sails</b> first <b>certified</b> after 15th March 2007	4650 mm

---

### OFFICIAL DOCUMENTS:

International 420 **Class Rules**

Lines plan (Plan des formes) issue C (August 2004)

Building specification (Drawing N° 5) issue J (August 2022)

International 420 **Rudder** Blade Drawing (August 2000)

International Measurement Form (December 2017)

Official templates used for measurement:

BOW (ISSUE C); C1 (ISSUE B); C2 (ISSUE B); C3 (ISSUE B); C4 (ISSUE B); C5 (ISSUE B); C6 (ISSUE B); C7 (ISSUE B); C8 (ISSUE B); C9 (ISSUE B); C10 (ISSUE B) AND STERN (ISSUE B or C).

Effective Date: 1<sup>st</sup> March 2025  
Published Date: 10<sup>th</sup> February 025  
Previous issue: 1<sup>st</sup> December 2023